

Technical Data Sheet

Compressor model **B30G5**
 Voltage **110-115V 60Hz ~1**
 Refrigerant **R134a**

APPLICATION

COMPRESSOR

MOTOR

Application	High Back Pressure	Displacement	3,10 cm ³	Nominal Power	1/10 hp
Refrigerant	R134a	Diameter	17,20 mm	Voltage/Frequency	110-115V 60Hz
Evaporating Temp.	-15,0 °C to 10,0 °C	Stroke	13,40 mm	Voltage range	94-127 V
Expansion	Capillar/Valve	Net Weight	4,80 Kg	Type	RSIR
Comp. Cooling	Static/Fan cooled	Oil type	POE 32	Phase number	1 PH
Max. ambient temp.	43,0 °C	Oil charge	120 cm ³	Locked Rotor Amps (LRA)	11,80 A
Compatible refriger.	R1234yf			Main W. resist. at 25°C	22,40 Ω
				Start W. resist. at 25°C	5,20 Ω

NOMINAL PERFORMANCE

APPROVALS

	ASHRAE	CECOMAF
Cooling Capacity	270 kCal/h	262 W
COP	2,08 W/W	1,79 W/W
EER	1,78 kCal/Wh	1,54 kCal/Wh
Input Power	151 W	147 W
Current	2,02 A	1,99 A

TEST CYCLE CONDITIONS

	ASHRAE HBP (D)	CECOMAF HBP (C)
Evaporating temp. (T _e)	7,2 °C	5,0 °C
Condensing temp. (T _c)	55,0 °C	55,0 °C
Liquid temp. (T _{liq.})	46,0 °C	55,0 °C
Ambient temp. (T _{amb.})	35,0 °C	32,0 °C
Suction temp. (T _{suction})	35,0 °C	32,0 °C
Voltage/Frequency	115 V 60 Hz	115 V 60 Hz

ELECTRICAL COMPONENTS

Relay	Option 1			
Reference	QL2-5.30 (013)			
Pick-Up	A			
Drop-Out	A			
Protector	Option 1			
Reference	DRB30V61A2 (233)			
Current				
Time check				
Disc temp. (Open/Close)				

ASHRAE

Tc °C	Te °C	Cooling Capacity kCal/h	Consumption W	Current A	COP W/W	EER kCal/Wh
40	-15	132	96	1,76	1,59	1,37
40	-10	173	102	1,78	1,98	1,70
40	-5	220	108	1,80	2,36	2,03
40	0	273	116	1,83	2,74	2,36
40	5	331	124	1,87	3,10	2,67
40	7,2	359	128	1,89	3,26	2,80
40	10	395	133	1,92	3,45	2,96

45	-15	120	98	1,77	1,41	1,22
45	-10	157	105	1,79	1,74	1,49
45	-5	200	113	1,82	2,06	1,77
45	0	249	122	1,86	2,38	2,05
45	5	303	131	1,91	2,69	2,31
45	7,2	329	136	1,93	2,82	2,42
45	10	363	142	1,96	2,98	2,56

50	-15	107	100	1,77	1,24	1,07
50	-10	141	109	1,80	1,51	1,30
50	-5	180	118	1,84	1,78	1,53
50	0	225	128	1,89	2,05	1,76
50	5	276	139	1,95	2,31	1,99
50	7,2	300	144	1,97	2,43	2,09
50	10	332	150	2,01	2,57	2,21

55	-15	95	102	1,78	1,08	0,93
55	-10	125	112	1,82	1,30	1,12
55	-5	160	122	1,86	1,53	1,31
55	0	201	134	1,92	1,75	1,51
55	5	248	146	1,99	1,98	1,70
55	7,2	270	151	2,02	2,08	1,78
55	10	300	159	2,07	2,20	1,89

60	-15	83	104	1,79	0,92	0,79
60	-10	109	115	1,83	1,10	0,94
60	-5	140	127	1,89	1,29	1,11
60	0	177	140	1,95	1,48	1,27
60	5	220	153	2,03	1,67	1,44
60	7,2	241	159	2,07	1,76	1,51
60	10	268	167	2,12	1,87	1,60

65	-15	71	106	1,80	0,77	0,66
65	-10	93	119	1,85	0,91	0,78
65	-5	120	132	1,91	1,06	0,91
65	0	154	145	1,99	1,23	1,06
65	5	192	160	2,07	1,40	1,20
65	7,2	211	167	2,12	1,47	1,26
65	10	237	176	2,18	1,57	1,35

CECOMAF

Tc °C	Te °C	Cooling Capacity W	Consumption W	Current A	COP W/W	EER kCal/Wh
40	-15	142	97	1,76	1,47	1,27
40	-10	187	102	1,78	1,82	1,58
40	-5	238	109	1,81	2,18	1,88
40	0	294	117	1,84	2,52	2,18
40	5	357	125	1,88	2,86	2,47
40	7,2	386	129	1,90	3,00	2,59
40	10	425	134	1,92	3,17	2,74

45	-15	128	99	1,77	1,30	1,12
45	-10	169	106	1,79	1,59	1,38
45	-5	215	114	1,83	1,89	1,63
45	0	267	122	1,86	2,18	1,88
45	5	325	132	1,91	2,46	2,13
45	7,2	352	137	1,94	2,58	2,23
45	10	389	143	1,97	2,72	2,35

50	-15	114	101	1,77	1,13	0,98
50	-10	150	109	1,81	1,38	1,19
50	-5	192	118	1,85	1,62	1,40
50	0	240	128	1,89	1,87	1,61
50	5	293	139	1,95	2,10	1,82
50	7,2	319	145	1,98	2,21	1,91
50	10	353	151	2,02	2,33	2,02

55	-15	101	103	1,78	0,98	0,84
55	-10	132	113	1,82	1,17	1,01
55	-5	170	123	1,87	1,38	1,19
55	0	213	134	1,92	1,58	1,37
55	5	262	147	1,99	1,79	1,54
55	7,2	285	152	2,03	1,87	1,62
55	10	317	160	2,07	1,98	1,71

60	-15	87	105	1,79	0,83	0,71
60	-10	114	116	1,84	0,98	0,85
60	-5	147	128	1,89	1,15	0,99
60	0	186	140	1,96	1,32	1,14
60	5	230	154	2,04	1,50	1,29
60	7,2	252	160	2,08	1,57	1,36
60	10	281	168	2,13	1,67	1,44

65	-15	73	107	1,80	0,68	0,59
65	-10	96	119	1,85	0,80	0,69
65	-5	124	132	1,91	0,94	0,81
65	0	159	146	1,99	1,08	0,94
65	5	199	161	2,08	1,23	1,07
65	7,2	218	168	2,13	1,30	1,12
65	10	245	177	2,19	1,38	1,19

EN12900

X	Cooling Capacity (W)	Consumption (W)	Current (A)	Mass Flow (kg/h)
1	510,6962302333	70,4512890994	1,5721076594	9,2181672016035
2	19,0672376966	-0,4990695320	-0,0053978546	0,36119068067427
3	-5,5116146858	1,2263143338	0,0067400419	-0,068382016190979
4	0,1155432896	0,0196130963	0,0002301398	0,0035217353426775
5	-0,1824123566	0,0538583178	0,0003444713	-0,0020566103494173

Equation	$x_1 + x_2Te + x_3Tc + x_4Te^2 + x_5TeTc$
----------	-------------------------------------------

Technical Data Sheet

COMPRESSOR DIMENSIONS

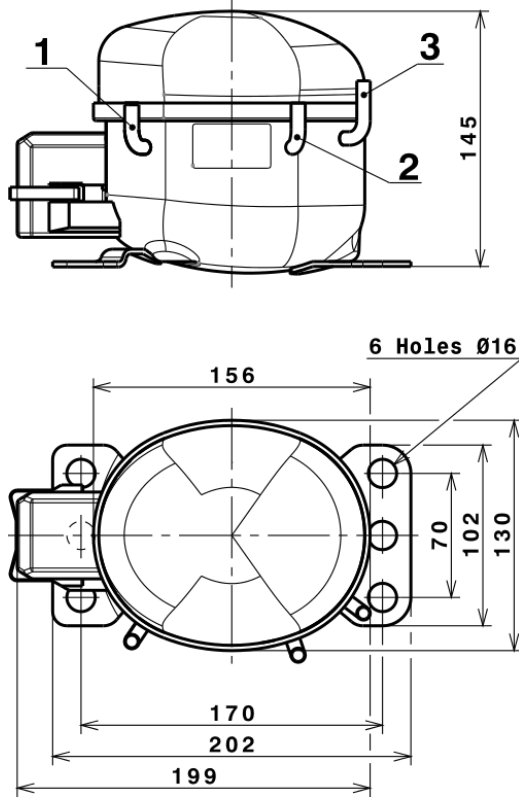

DESIGNATION	INTERNAL DIAM.
1 Suction	6,1 mm
2 Service	6,1 mm
3 Discharge	5,1 mm

WIRING DIAGRAMS AND ELECTRICAL ASSEMBLY

RSIR CONNECTION (RELAY) (B, Small L ranges)

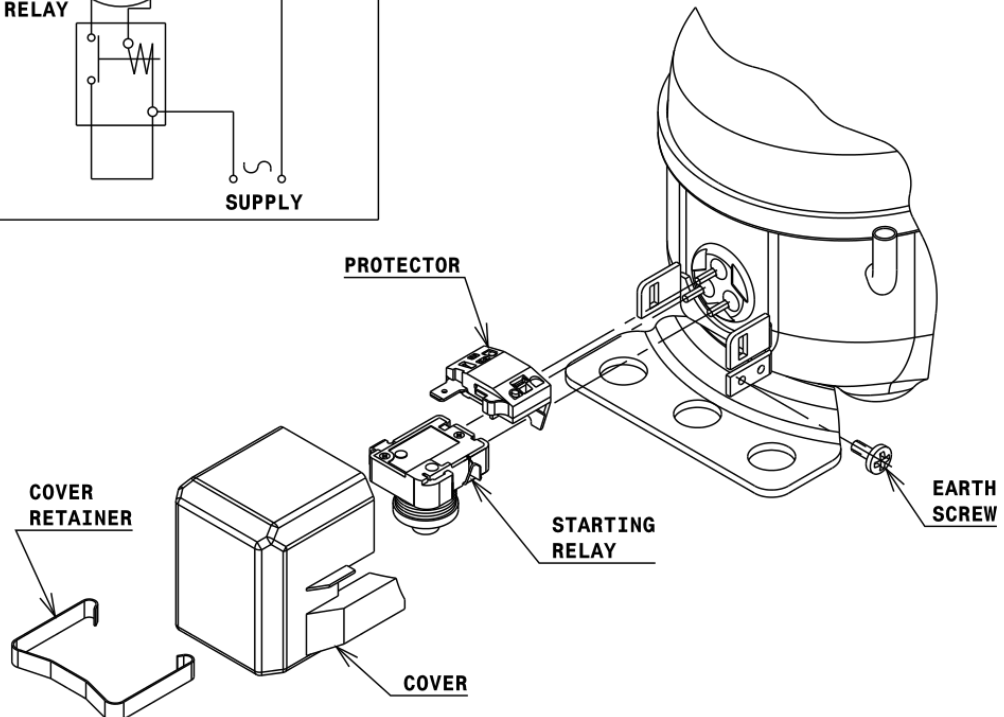
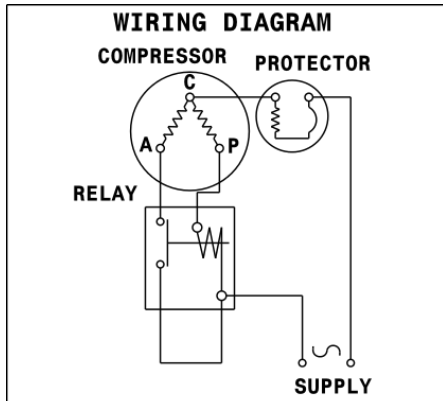

FIXINGS

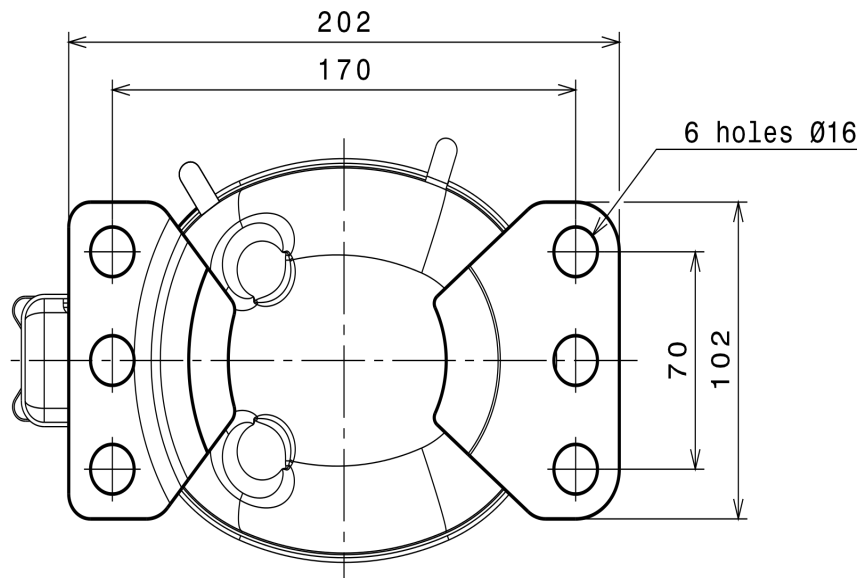

SILENT BLOCKS (MOUNTING ACCESSORIES)

STANDARD

Ø16 holes (170x70 net)

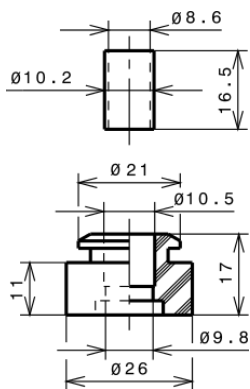

SOA

SOA R134a HBP

