

Technical Data Sheet

Compressor model **B30G**
 Voltage **220-240V 50Hz ~1**
 Refrigerant **R134a**

APPLICATION

COMPRESSOR

MOTOR

Application	High Back Pressure	Displacement	3,10 cm ³	Nominal Power	1/10 hp
Refrigerant	R134a	Diameter	17,20 mm	Voltage/Frequency	220-240V 50Hz
Evaporating Temp.	-15,0 °C to 10,0 °C	Stroke	13,40 mm	Voltage range	187-255 V
Expansion	Capillar/Valve	Net Weight	3,80 Kg	Type	RSIR
Comp. Cooling	Static/Fan cooled	Oil type	POE 32	Phase number	1 PH
Max. ambient temp.	43,0 °C	Oil charge	120 cm ³	Locked Rotor Amps (LRA)	4,00 A
Compatible refriger.	R1234yf			Main W. resist. at 25°C	29,50 Ω
				Start W. resist. at 25°C	24,50 Ω

NOMINAL PERFORMANCE

	ASHRAE	CECOMAF
Cooling Capacity	234 kCal/h	229 W
COP	2,06 W/W	1,77 W/W
EER	1,77 kCal/Wh	1,53 kCal/Wh
Input Power	132 W	129 W
Current	0,89 A	0,88 A

APPROVALS



TEST CYCLE CONDITIONS

	ASHRAE HBP (D)	CECOMAF HBP (C)
Evaporating temp. (T _e)	7,2 °C	5,0 °C
Condensing temp. (T _c)	55,0 °C	55,0 °C
Liquid temp. (T _{liq.})	46,0 °C	55,0 °C
Ambient temp. (T _{amb.})	35,0 °C	32,0 °C
Suction temp. (T _{suction})	35,0 °C	32,0 °C
Voltage/Frequency	220 V 50 Hz	220 V 50 Hz

ELECTRICAL COMPONENTS

Relay	Option 1			
Reference	QP2-22 (002)			
Voltage	V			
Resistance	Ω			
Protector	Option 1			
Reference	DRB18P61A1 (067)			
Current				
Time check				
Disc temp. (Open/Close)				

ASHRAE

Tc °C	Te °C	Cooling Capacity kCal/h	Consumption W	Current A	COP W/W	EER kCal/Wh
40	-15	110	87	0,79	1,47	1,27
40	-10	150	93	0,80	1,88	1,62
40	-5	191	98	0,81	2,26	1,95
40	0	234	104	0,82	2,62	2,26
40	5	279	110	0,83	2,97	2,55
40	7,2	300	112	0,84	3,11	2,68
40	10	326	115	0,84	3,29	2,83

45	-15	100	89	0,79	1,30	1,11
45	-10	137	96	0,80	1,66	1,42
45	-5	175	103	0,81	1,99	1,71
45	0	216	109	0,83	2,30	1,98
45	5	258	116	0,84	2,60	2,23
45	7,2	278	119	0,85	2,72	2,34
45	10	303	122	0,86	2,87	2,47

50	-15	89	92	0,80	1,13	0,97
50	-10	124	99	0,81	1,45	1,24
50	-5	160	107	0,82	1,74	1,49
50	0	198	115	0,84	2,01	1,73
50	5	238	122	0,86	2,26	1,95
50	7,2	256	125	0,87	2,37	2,04
50	10	279	130	0,89	2,50	2,15

55	-15	79	94	0,80	0,97	0,83
55	-10	110	103	0,81	1,25	1,07
55	-5	144	111	0,83	1,50	1,29
55	0	180	120	0,86	1,74	1,50
55	5	217	128	0,88	1,96	1,69
55	7,2	234	132	0,89	2,06	1,77
55	10	256	137	0,91	2,17	1,87

60	-15	68	97	0,80	0,82	0,70
60	-10	97	106	0,82	1,06	0,92
60	-5	128	116	0,84	1,29	1,11
60	0	161	125	0,87	1,50	1,29
60	5	196	135	0,90	1,69	1,45
60	7,2	212	139	0,92	1,77	1,52
60	10	232	144	0,94	1,87	1,61

65	-15	57	99	0,81	0,67	0,58
65	-10	84	110	0,83	0,89	0,77
65	-5	113	120	0,86	1,09	0,94
65	0	143	131	0,89	1,27	1,10
65	5	175	141	0,93	1,44	1,24
65	7,2	190	146	0,94	1,52	1,30
65	10	209	152	0,97	1,60	1,38

CECOMAF

Tc °C	Te °C	Cooling Capacity W	Consumption W	Current A	COP W/W	EER kCal/Wh
40	-15	119	87	0,79	1,36	1,17
40	-10	161	93	0,80	1,73	1,50
40	-5	206	99	0,81	2,09	1,80
40	0	252	104	0,82	2,42	2,09
40	5	301	110	0,83	2,73	2,36
40	7,2	322	113	0,84	2,86	2,47
40	10	351	116	0,85	3,03	2,61

45	-15	107	90	0,79	1,19	1,03
45	-10	147	97	0,80	1,52	1,31
45	-5	188	103	0,82	1,82	1,57
45	0	232	110	0,83	2,11	1,82
45	5	277	117	0,85	2,37	2,05
45	7,2	297	119	0,85	2,49	2,15
45	10	324	123	0,87	2,63	2,27

50	-15	95	92	0,80	1,03	0,89
50	-10	132	100	0,81	1,32	1,14
50	-5	170	108	0,82	1,58	1,37
50	0	211	115	0,84	1,83	1,58
50	5	253	123	0,86	2,06	1,78
50	7,2	272	126	0,87	2,15	1,86
50	10	297	131	0,89	2,27	1,97

55	-15	83	95	0,80	0,88	0,76
55	-10	117	103	0,82	1,13	0,98
55	-5	152	112	0,84	1,36	1,18
55	0	190	121	0,86	1,57	1,36
55	5	229	129	0,88	1,77	1,53
55	7,2	247	133	0,90	1,86	1,60
55	10	270	138	0,91	1,96	1,69

60	-15	71	97	0,80	0,73	0,63
60	-10	102	107	0,82	0,95	0,82
60	-5	134	116	0,85	1,15	1,00
60	0	169	126	0,87	1,34	1,16
60	5	205	136	0,91	1,51	1,31
60	7,2	222	140	0,92	1,59	1,37
60	10	243	145	0,94	1,68	1,45

65	-15	59	100	0,81	0,59	0,51
65	-10	87	110	0,83	0,79	0,68
65	-5	117	121	0,86	0,96	0,83
65	0	148	131	0,89	1,13	0,97
65	5	181	142	0,93	1,28	1,10
65	7,2	196	147	0,95	1,34	1,16
65	10	216	153	0,97	1,42	1,23

EN12900

X	Cooling Capacity (W)	Consumption (W)	Current (A)	Mass Flow (kg/h)
1	419,1651016306	62,9226261956	0,6919630194	7,4952064473034
2	14,3533275954	-0,3963036013	-0,0033012878	0,2601970516187
3	-4,2561626081	1,1060937095	0,0031858074	-0,047802430253466
4	0,0375307059	0,0015415110	0,0000766934	0,0014112174358487
5	-0,1245369721	0,0398985665	0,0001578848	-0,00097871505832825

Equation	$x_1 + x_2Te + x_3Tc + x_4Te^2 + x_5TeTc$
----------	---

Technical Data Sheet

COMPRESSOR DIMENSIONS

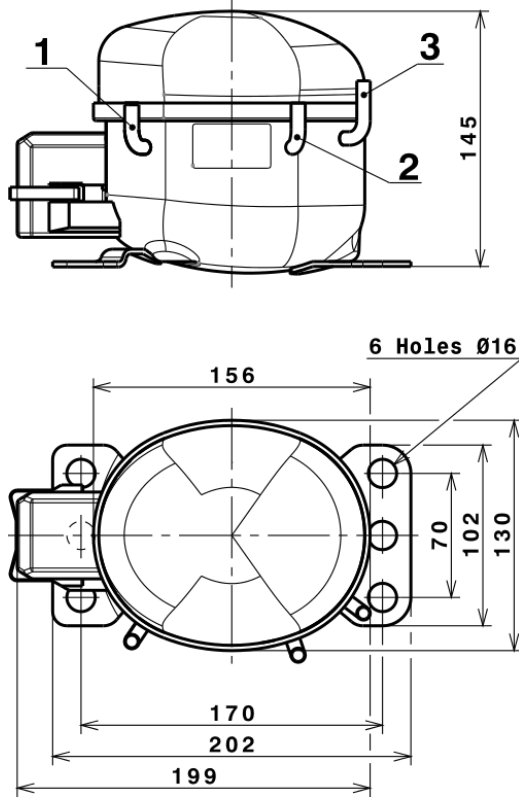

DESIGNATION	INTERNAL DIAM.
1 Suction	6,1 mm
2 Service	6,1 mm
3 Discharge	5,1 mm

WIRING DIAGRAMS AND ELECTRICAL ASSEMBLY

RSIR CONNECTION (PTC) (B, Small L ranges)

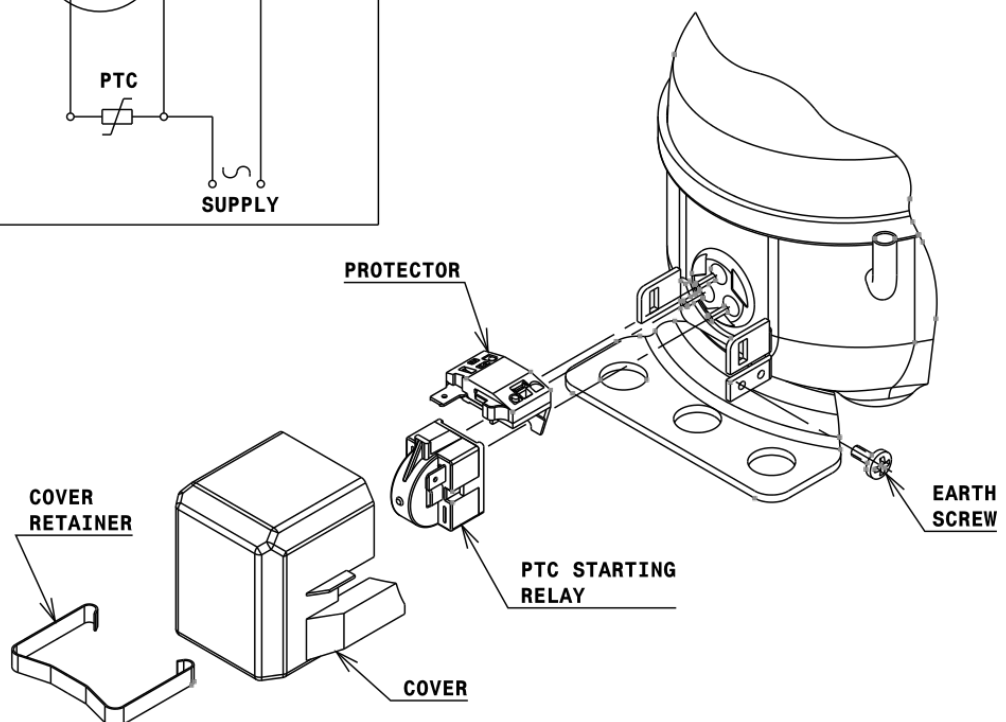
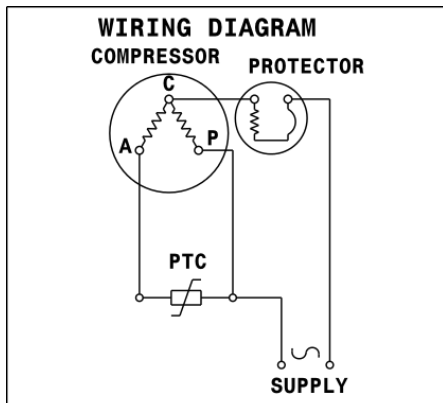

FIXINGS

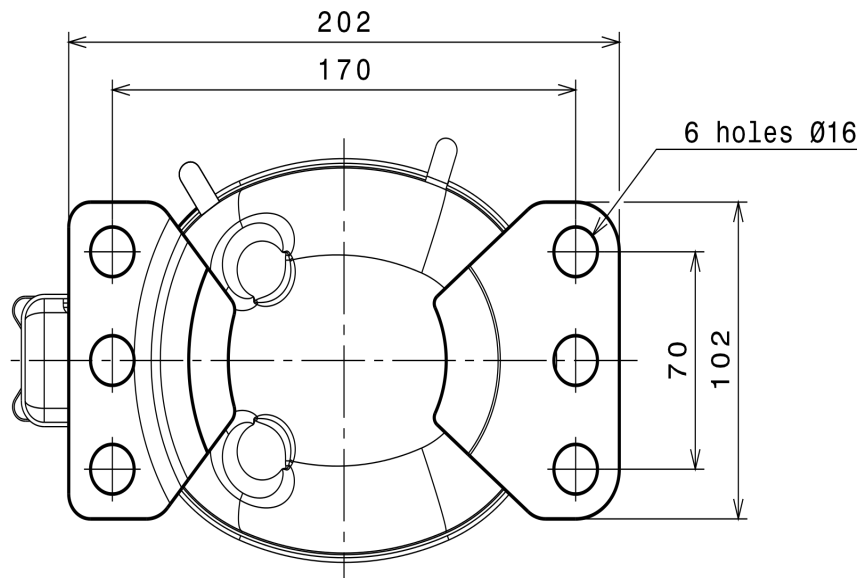

SILENT BLOCKS (MOUNTING ACCESSORIES)

STANDARD

Ø16 holes (170x70 net)

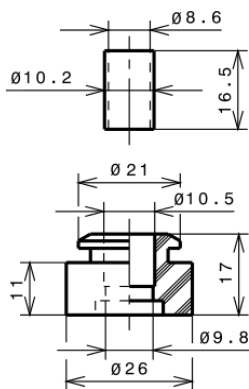

SOA

SOA R134a HBP

